

Revised: 29<sup>th</sup> September 2017

## Installation Manual

# Elite

Reference Number: **INST 003-2017**

### Description

Elite Stairways conform to DIN 4570, are manufactured from high strength die-cast aluminium alloy components and have a load bearing of 200kgs. The stairway is attached to a 19mm thick wooden backboard, 600mm wide x 200mm deep, for fitting to the structural vertical surface.

The stairway is supplied with two heavy-duty counter-balanced springs (item 7), incorporated into pivot brackets to ensure that the stairway can be raised and lowered with minimum effort.

All Elite stairway units are supplied with a telescopic handrail for use where the size of the ceiling opening/hatch box permits. Both sections are adjustable and must be configured by the installer to suit their specific installation requirements. The bottom section of the handrail is static, whereas the top section slides within the bottom section to extend and retract when the ladder is opened and closed. The securing screws on the underside of the handrail fixing brackets should be used to adjust the length of the top section. Ensuring that the handrail doesn't interfere/conflict with the interior of the hatch box or the roof hatch above, while also achieving the maximum length possible within the installation.

The maximum fixing height from the floor to underside of the backboard is 3390mm. Selection of the correct stairway for the floor level to fixing height is determined as follows:

- Elite stairway supplied with 9 treads, 350mm wide x 140mm deep, to suit a floor to underside of the backboard height of 2250mm - 2500mm.
- Elite stairway supplied with 10 treads, 350mm wide x 140mm deep, to suit a floor to underside of the backboard height of 2501mm - 2790mm.
- Elite stairway supplied with 11 treads, 350mm wide x 140mm deep, to suit a floor to underside of the backboard height of 2791mm - 3090mm.
- Elite stairway supplied with 12 treads, 300mm wide x 140mm deep, to suite a floor to underside of the backboard height of 3091mm - 3390mm.

Revised: 29<sup>th</sup> September 2017

## Installing the Stairway

First, check that the correct stairway has been received to suit the actual floor to fitting height as detailed above.



**Please Note:** It is not possible to stretch the stairway out to its full length until it has been fixed in position.

When the Elite Stairway is fitted to a vertical structural surface greater than 400mm underneath a roof hatch, a spacer the same size as the backboard (200mm high x 580mm wide and a minimum of 50mm deep) needs to be positioned between the vertical structural surface and the backboard (item 12) of the stairway. This will allow for the stairway to be folded back into the closed position. The spacer is not supplied with the stairway (available as an optional accessory from Premier Loft Ladders).



**Please Note:** The stairway must be fitted in the closed position.

There are no pre-drilled holes in the backboard. We recommend a minimum of 6 No. suitable screws (item 10), min. Ø8mm x 80mm, complete with Ø9mm washers (item 11).

Screws are included with the stairway, but the suitability of the supplied fixings will depend upon the actual surface that the stairway is being fitted to. Ensure the backboard is fixed to solid structural material. Once the stairway has been correctly fitted, it can then be lowered to the floor surface.

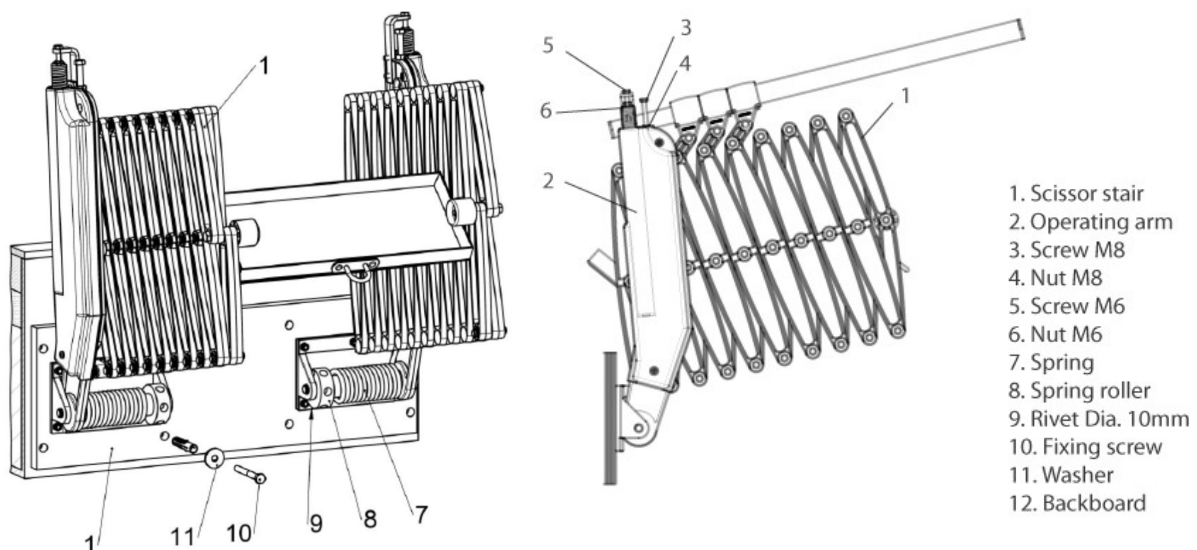

Revised: 29<sup>th</sup> September 2017

## Adjustment of the touch-down point after installing the stairway.

The actual touch-down point (floor contact) of the stairway can be adjusted to suit individual stairways as follows:

Extend the stairway out to the desired touch-down point (15° is the minimum angle). Slacken the lock nut (item 4) and turn the adjustment bolt (item 3) until it stops. Tighten the lock nut; the stairway will be set to extend to this touch-down point.

Once any adjustment has been carried out we would recommend that you check that the treads are horizontal to the floor.

The angle of the treads can be adjusted by slackening the two nuts on the underside of each tread. Reset all treads on the stairway so that they are horizontal.

## Adjusting the drop rate/speed after installing the Stairway

Loosen the lock nuts (item 6), adjust the spring tension by turning the adjustment screw (item 5). Ensure that care is taken that components do not twist out of position. The components must be aligned and parallel to the operating arm (item 2). Hold the spring in position (to prevent further rotation and misalignment) and tighten the lock nut.

Both springs must be adjusted equally.

## Adjusting the Spring Tension of the Stairway

The stairway is supplied with the correct spring tension, which is set at the factory. If the spring tension needs to be adjusted, we recommend that this is only carried out by a suitably qualified Maintenance Engineer.



*Please Note: Spring adjustment must be carried out with the stairway in the closed position.*

Revised: 29<sup>th</sup> September 2017

It is important that a Ø10mm x 300mm long steel bar ('Tommy Bar') is used in the locating holes of the die-cast spring roller (item 8).

To increase the tension, place the steel bar in the hole next to the domed headed stud (item 9) and rotate until the stud can be removed.

Rotate the spring roller until it is possible to place the stud into the next hole adjacent to where the stud was removed. Once it is safely in position allow the roller to rotate slowly back so that the stud is back against the bracket and remove the steel bar.

Both springs must be adjusted equally.



***Please Note:** The Springs (item 7) are under high tension so extreme caution and care must be taken when carrying out any adjustment. It is important that the correct size Steel Bar is used, if any doubt please contact us and ask to speak to a Technical Advisor.*