



Aluminium Concertina Loft Ladders...



Access
all areas

Supreme loft ladder

...lightweight, strength and durability



The Supreme heavy duty aluminium loft ladder is manufactured from quality die-cast aluminium alloy components for strength and light-weight operation. The wooden hatch box and insulated trapdoor provide excellent energy efficiency.

- Heavy duty ladder, rated to 200kg per tread.
- Ease of use, requiring operating forces of less than 3kg.
- Fully insulated hatch with an airtight seal.
- Large treads with anti-slip profile for comfort and safety.
- Suitable for very high ceilings.
- Available in standard sizes or made-to-order with a wide range of options and accessories.

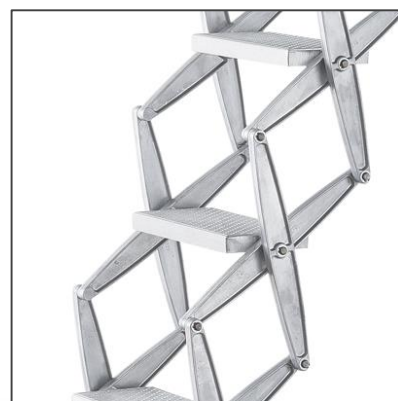
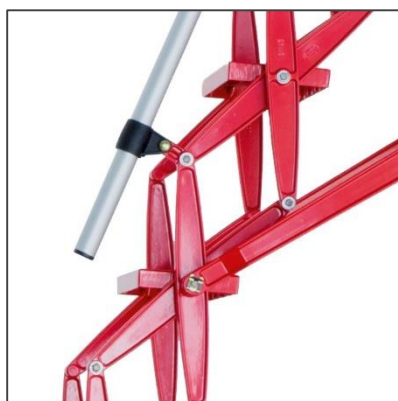

sales@premierloftladders.com

www.premierloftladders.com

PREMIER
LOFT LADDERS

Supreme DD loft ladder

...upper hatch for superb energy efficiency



The Supreme DD loft ladder offers the same benefits as the Supreme, with enhanced thermal insulation due to a secondary upper cover. Also, the upper cover can be closed immediately after entering the loft, therefore minimising the loss of warm air.

- Heavy duty ladder, rated to 200kg per tread.
- Ease of use, requiring operating forces of less than 3kg.
- Fully insulated hatch with an airtight seal.
- Large treads with anti-slip profile for comfort and safety.
- Available in standard sizes or made-to-order with a wide range of options and accessories.

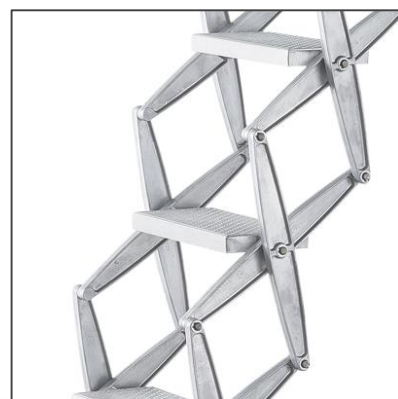
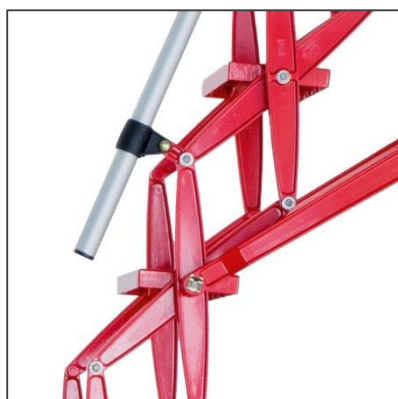

sales@premierloftladders.com

www.premierloftladders.com

PREMIER
LOFT LADDERS

Elite loft ladder

...strength, durability and ease of operation



The Elite is ideal for a renovation project or replacement of an old loft ladder as it can be conveniently installed within an existing ceiling opening or hatch box. It is manufactured from high quality die-cast aluminium alloy components for strength and durability.

- Heavy duty ladder, rated to 200kg per tread.
- Ease of use, requiring operating forces of less than 3kg.
- Easy to install.
- Space-saving retractable loft ladder for small ceiling openings.
- Large treads with anti-slip profile for comfort and safety.
- Telescopic handrail as standard.

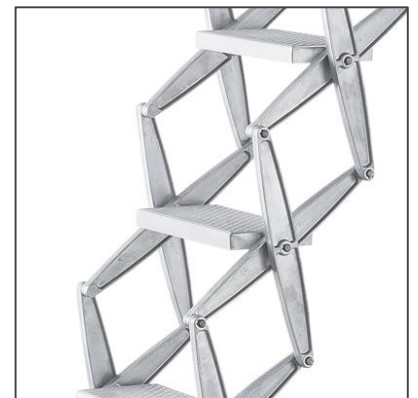
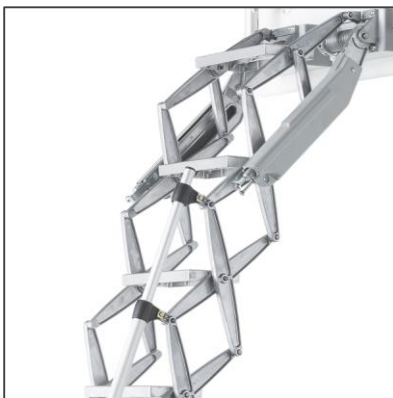

sales@premierloftladders.com

www.premierloftladders.com

PREMIER
LOFT LADDERS

Elite Vertical loft ladder

...strength, durability and ease of operation



The Elite Vertical features a damped hinge mechanism to allow the Elite loft ladder to be utilised in vertical applications, such as on a mezzanine floor or in a wall hatch. It is manufactured from high quality die-cast aluminium alloy components for strength and durability.

- Heavy duty ladder, rated to 200kg per tread.
- Ease of use, requiring operating forces of less than 3kg.
- Easy to install.
- Space-saving retractable loft ladder for small openings.
- Large treads with anti-slip profile for comfort and safety.
- Telescopic handrail as standard.

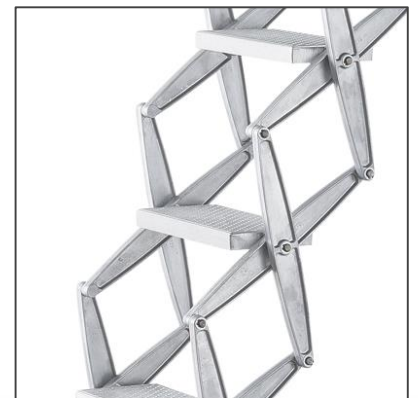
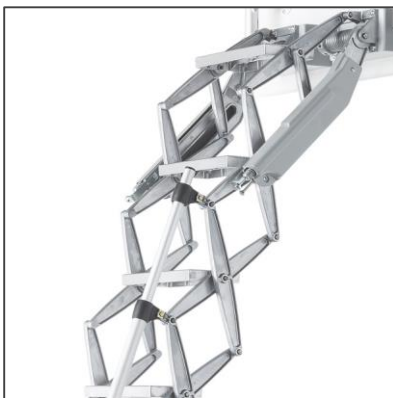

sales@premierloftladders.com

www.premierloftladders.com

PREMIER
LOFT LADDERS

Mini loft ladder

...ideal for small ceiling openings

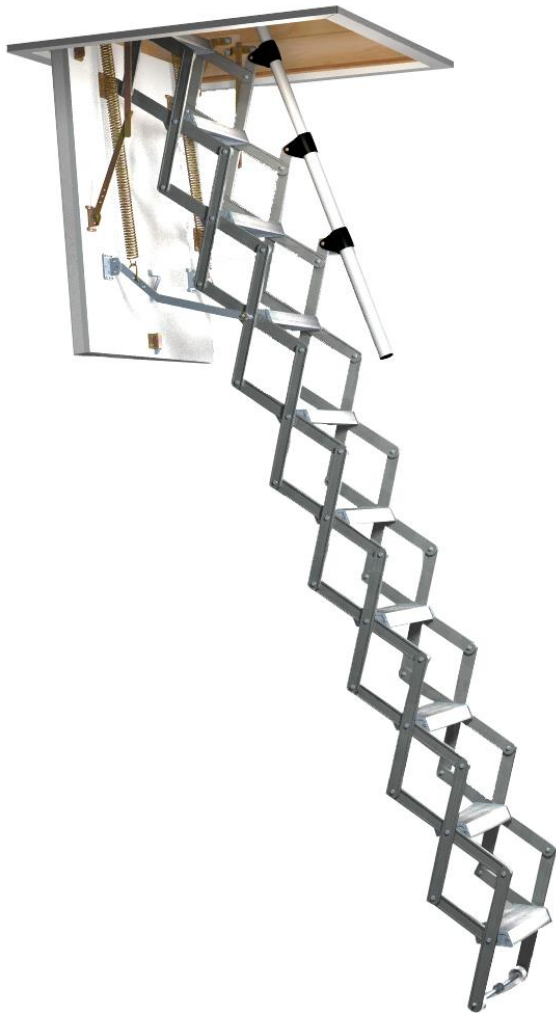

The Mini aluminium loft ladder is specially designed for small ceiling openings. It is supplied as a ready to fit unit, consisting of a space-saving aluminium ladder contained within an insulated hatch box.

- Retractable loft ladder for small ceiling openings.
- Lightweight and durable aluminium ladder.
- Fully insulated hatch with an airtight seal.
- Load rated to 150kg per tread.
- Hatch box trap door finished in white on both sides.
- Easy to operate.

Also available:

- 'MiniLine' fire rated loft ladder



sales@premierloftladders.com

www.premierloftladders.com

PREMIER
LOFT LADDERS

Piccolo Premium loft ladder

...easy to operate and perfect for very small ceiling openings



The Piccolo Premium loft ladder is easy to fit and manufactured from aluminium alloy components. Suitable for very small ceiling openings and for use in an existing hatch box.

- Space-saving retractable loft ladder for very small ceiling openings.
- Lightweight and durable aluminium ladder.
- Load capacity of 150kg per step.
- Spring assisted operation.
- Easy to install.

Also available:

- 'Piccolo' without spring mechanism.
- 'Piccolo Premium Vertical' for use on mezzanine floors and in wall hatches.

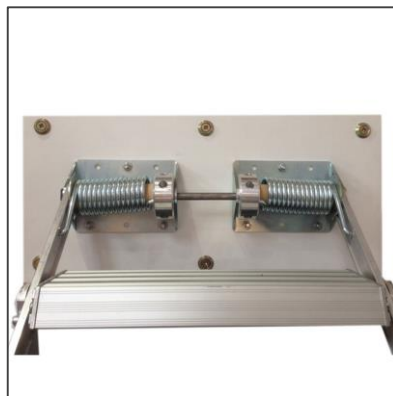
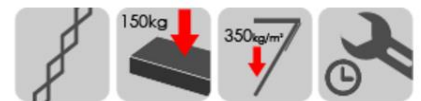

sales@premierloftladders.com

www.premierloftladders.com

PREMIER
LOFT LADDERS

The
preferred
choice



2 Dawson Drive, Trimley St Mary
Felixstowe, Suffolk, IP11 0YW, UK

T: 01394 214413 or 0845 9000 195

E: sales@premierloftladders.com

W: www.premierloftladders.com